



BESTCHROM

博 格 隆

BXK300 Industrial scale chromatography column Instruction for use



Contents

1. Introduction	1
2. Installation and alignment.....	3
3. Column packing	7
4. Evaluation of Packing	9
5. Maintenance	10
6. Handling Information.....	12
7. Appendix	14
8. Ordering information	19

1. Introduction

1.1 Overview

BXK300 series chromatographic column is a high precision sanitary chromatographic column specially designed for the large-scale production of biomolecule drugs. It is suitable for the packing of resins in low pressure chromatographic columns.

BXK chromatography column is composed of three parts: adaptor, column body and stand. The basic structure includes glass tube, flange, O-ring, screens, support nets, deflector, end-piece and rods. The rods hold the flange and end-piece to the glass tube which is sealed by O-rings. The O-ring can not only avoid the direct contact between the glass tube and the end-piece, but also ensure the sealing of the glass tube.

The adaptor and end-piece are designed for single pipe use. The adaptor and end-piece are covered with a large pore support net, a fine pore screen and deflector. When choosing screen, screen with different pore sizes (23 μ m (polypropylene) or 10 μ m (nylon)) are available.

Different column heights can be set by adjusting the height of adaptor. The column can be sealed by compressing or loosening the seal ring.

The end-piece is mounted on the stand, which is equipped with a universal wheel for easy movement. The foot brake on the universal wheel can fix the column.

1.2 Material

The BXK300 series chromatography column is a glass chromatography columns developed for industrial scale purification. All materials used meet the requirements of SFDA for pharmaceutical manufacturers, so it is an ideal choice for industrial production. Listed are main characteristics the column:

- ① Column body is made of medical grade 316L stainless steel.
- ② The glass part of tube body is made of imported high-precision medical glass, of which roundness error is less than 0.1mm.
- ③ Screen, support nets and deflector are made of imported materials, enable tolerance with a variety of acid /alkali solutions and organic solvents;
- ④ O-ring made of EPDM material, offering better sealing and durability.
- ⑤ Adaptor which enables adjustable bed height.

All parts of the chromatography column have complete material certification, meeting requirements of pharmaceutical industry.

1.3 Technical specifications and materials (next page)

1.3.1 Technical Specifications

Specifications	Diameter (mm)	Floor area (cm ²)	Column Height (cm)	Bed height(cm)		Volume(L)		Max Pressure (bar/g)	Total weight (kg)	Chromatographic column inlet dimension	Adaptor weight (kg)	Outline dimension (cm) D×W×H
				Min	Max	Min	Max					
BXK300/500	296	688	50	0	33	0	22.7	4.0	68	10mm	29	69×69×135
BXK300/750	296	688	75	25	54	17.2	37.2	4.0	73			69×69×160
BXK300/950	296	688	95	45	72	31.0	49.6	4.0	78			69×69×180

1.3.2 Material

Specifications	Supporting net	Screen	Column tube	Seal ring	Deflector	Holder
BXK 300/500	PP	10μm nylon (PA)	Glass	EPDM	PP	316L stainless steel
BXK 300/750		23μm PP				
BXK 300/950						

2. Installation and alignment



2.1 Installation and inspection of new chromatography column

- Unpacking the carton, check whether the goods are complete and in good condition according to the packing list, for any problem, please contact the Bestchrom sales representative immediately.
- Since the column and column frame are transported separately, it is necessary to first install the wheel foot on the column frame, then ,mount the column on the column frame and tighten the fixing screws with a wrench.
- Wet the seal ring with 20% ethanol and loosen the sealing ring.
Note: Due to the strong friction between the dry sealing ring and glass tube, keep the sealing ring wet when moving the adaptor inside the column to prevent damaging the sealing ring.
- Dismount the adaptor and check whether the flange nut to fix the adaptor is loose. If so, please use a torque wrench with torque distance, set the torque to 4N/M, and tighten it.
Note: Force exceeding 4N/M may damage the glass tube.
- Check and ensure that the anti-switch key is in the socket of the adaptor's outer tube. Adjust the anti-swivel screw to keep it in proper position.
- Connect column fittings, such as valves and pipes.

2.2 Assembly and disassembly of chromatography column

The following steps are the column mounting process before leaving the factory. Users can refer to this method for assembly and disassembly in reverse order.

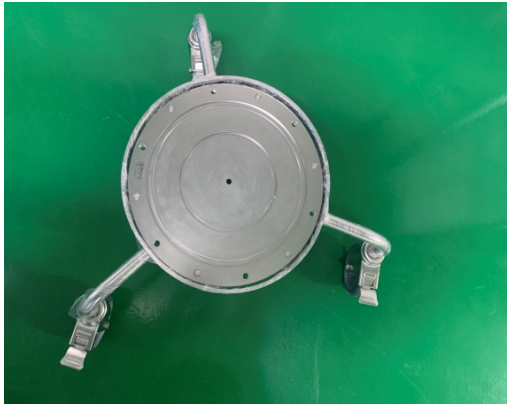
1) Assembly of column frame

<p>a. Install the three universal wheels on the stand and adjust the level of the stand.</p>	<p>b. Install the end-piece on the assembled stand, add the gasket and tighten it with the stand fixing screws.</p>
	
<p>c. Place the guide plate face up in the middle of the chassis and clamp it into the chassis groove. Then place the lower support net evenly in the center of the chassis and clamp the lower screen net in the outer ring groove of the chassis.</p>	
	

2) Assembly of glass tubes

a. Screw the 4 rods for tube into the installed stand. Make sure insert each rod at the same depth.



b. Put in glass tube, glass tube should be directly opposite the lower O-ring.



c. Buckle the upper O-ring into the flange.



d. The inverted flange is placed flat on the glass tube, and the 6 screw holes on the flange are exactly corresponding to the 6 screw rods.

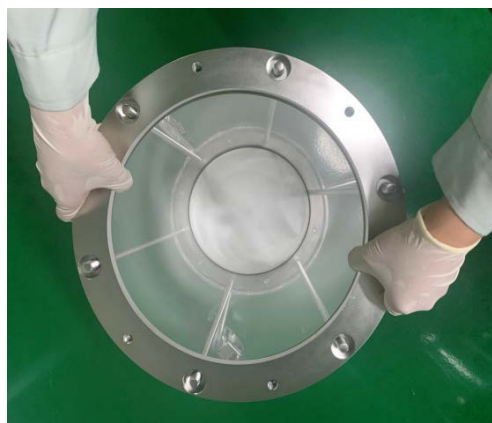

e. Put in the gasket and tighten with a torque wrench.

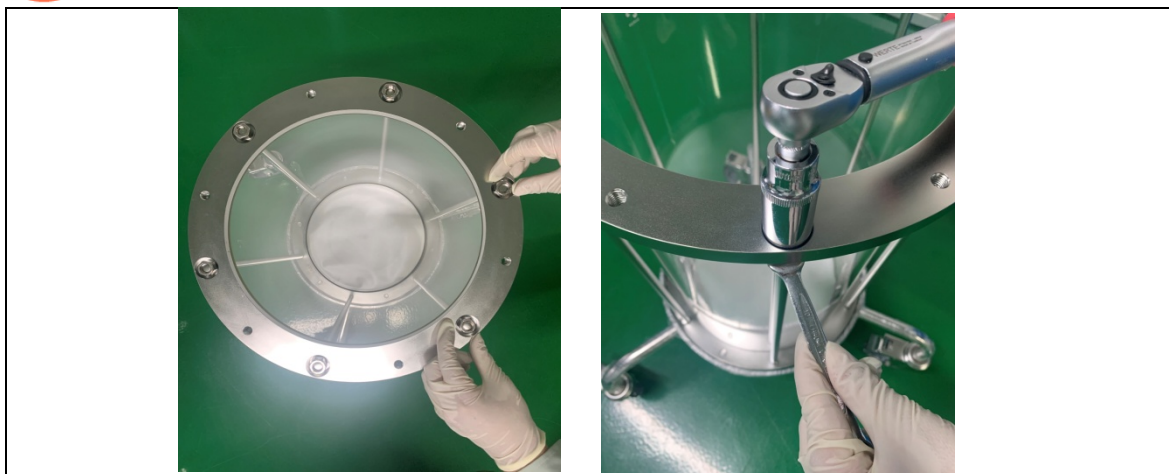

3) Adaptor assembly

a. Put the column horizontally (avoid hard material knock against the column), the guide plate is stuck in the groove below the adapter plate, and then install the support network, screen, and then the cylinder seal ring is stuck in the middle of the sealing unit and the adapter plate.

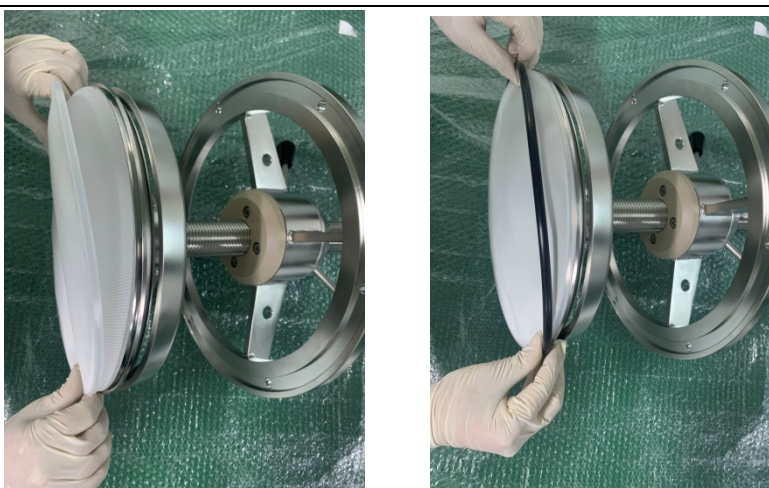

b. Install the installed adaptor into the glass tube

c. If external pipes are required, place gaskets evenly between the pipes and the cylinder, then lock them with clamps and tighten them.



3. Column packing

3.1 Cleaning and moistening

- The column can be packed with 0.5M NaOH and kept for more than 1 hour. Then rinse with purified water.
- Inject about 10cm height of purified water to column, remove the bubbles in screen bottom, For tiny bubbles that are difficult to be drained, pump them out by rubber suction bulb, or by a peristaltic pump connected with a hose.
- Pump away excessive purified water, retain about 2cm height of purified water in the column.
- Close the bottom valve.

3.2 Packing step

- Use a gradienter to adjust the column to level and fix it.
- Tighten the valve at the bottom, slowly pour the slurry into the column at one time (use a packing reservoir if necessary). Do not bring any air bubbles into the column.
Packing reservoir: Empty glasstube with same diameter as the BXK column.
- After pouring, stir well again with a rod, and then flush the resin particles on the inner wall of the column from top to bottom with the packing solution, and let the resin settle naturally until there is about 1cm of clarifying solution on the suspension.
Note: This step reduces the resin particles sticking between the sealing ring and the column inner wall, eliminating the risk of leakage.

- Mount the adaptor, connect the upper cylinder to the chromatography system or peristaltic pump by installing a four-way double-pass valve.
- Lower the adapter to contact with the clarifying solution, gently shaking the adaptor to remove bubbles under the screen from the edge of the sealing ring, drain the bubbles under the screen. Tighten the sealing ring slightly and turn the four-way double-way valve switch to bypass.
- Move the cylinder downwards by rotating the adaptor, at which point the liquid is drained via a bypass of the cylinder's four-way double-pass valve. When no bubbles are discharged from the bypass, rotate the valve until it is connected with the pump.
Note: one person is responsible for fixing the adaptor, and the other is responsible for rotating the regulator. When rotation proved to be difficult, rotate the adaptor in the opposite direction, make sure that it is not stuck and then continue adjust vertically, otherwise it is easy to cause damage to the outer rod thread of the adaptor.
- Open the bottom valve, set the flow rate, turn on the pump, start packing the column.
Note: Different resins have different packing methods. Please refer to the resin manual to set the packing rate or pressure.
Meanwhile, set an alarm pressure during packing process to prevent damage caused to resin and column due to overpressure.
- Pack the column till the resin surface is stabilized, mark the bed height on the column
- Stop the pump and seal the bottom outlet of the column.
- Loosen the O-ring, and quickly adjust the upper screen to 0.5cm above resin surface.
- Tighten the O-ring, open the outlet at the bottom of the column, and open the pump at the same time.
- Continue to press the resin till its surface is stabilized. Mark the bed height and turn off the pump.
- At the same time, the other end of the four-way double-way valve is put into a beaker filled with liquid column (to prevent bubble suction), at the same time, the switch is rotated, the sealing ring of the cylinder head is slightly relaxed, and the cylinder head is pressed 3-5mm below the marked position (note: the liquid is drained from the four-way double-way valve at this time).
- Tighten the O-ring, close the bottom valve, and complete column packing.

Note: After column packing, packing solution above the adaptor can be sucked out by peristaltic pump and washed with purified water for 2~3 times to prevent the

potential corrosion of salt-containing solution on the column, 20% ethanol or 0.1M NaOH can be filled above the adaptor to prevent growth of bacteria in the column.

4. Evaluation of Packing

- Test the column efficiency to check the quality of packing. The tests are required after the column packing, during the column working life and when the separation and purification performance is deteriorated. The method of the expressing the efficiency of a packed column is in terms of the height equivalent to a theoretical plate (HETP) and the asymmetry factor (As).
- Acetone or NaCl can be used as sample for the testing. Sample solution and eluent buffer can be prepared according to the following table.

	Acetone method	NaCl method
Sample	1.0% (v/v) acetone in water	0.8M NaCl in water
Loading	1.0% CV	1.0% CV
Buffer	Water	0.4M NaCl in water
Flow rate	30 cm/h	30cm/h
Monitor	UV 280 nm	Conductivity

- Method for measuring HETP and As
According to the UV curve or the conductivity curve to calculate the column efficiency (HETP), and the asymmetry (As):

$$\text{HETP} = L/N$$

$$N = 5.54(V_R/W_h)^2$$

Note :

VR = retention volume

Wh = half-peak width

L = column height

N = the number of theoretical plates

(The units of V_R and W_h should be the same)

$$A_s = b/a$$

Note :

a = First half-peak width at 10% peak height

b = second half-peak width at 10% peak height

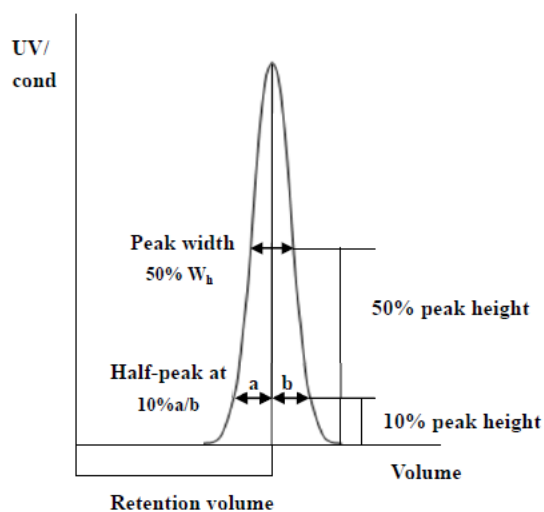

The theoretical plate number can vary with the detection conditions, so it can only be used as a reference value. The results are comparable only when the instruments and conditions remain unchanged. Solute, solution, eluent, sample volume, flow rate, flow path, temperature and other conditions all affect the results. For best results, sample loading should be controlled to less than 2.0% of column volume and linear flow rate should be 20-30cm /h.

- Evaluation the column packing

As a guideline, if the value of HETP is less than 3 times the average particle size (d_{50}) of the resin and the A_s is between 0.8~1.5, column is very efficient. The unsatisfactory result need to be analyzed and re-packing is necessary.

- For fillers of different particle sizes, the column efficiency is considered to be ideal when the following values are reached:

Particle size (μm)	Product	N/m	A_s
34	Bestarose HP	>8000	0.8-1.5
34	Chromdex	>10000	0.7-1.3
90	Bestarose FF	>3000	0.8-1.5
90	Bestarose XL	>3000	0.8-1.5
75~90	Diamond	>3500	0.8-1.5
200	Bestarose BB	>2000	0.8-1.5

5. Maintenance

Chromatographic column is a sophisticated scientific research and production equipment, and a good chromatographic state is very important to the experimental results or the quality of the products produced.

- All liquids and samples used in the column need to be filtered through a 0.45 μm membraneto remove particles to prevent blocking the column screen.
- After being used for a long time, the permeability of the net may decrease due to protein denaturation and other reasons, which are often indicated by the increase in back pressure. In that case, it is necessary to clean or replace the net separately. It is recommended to replace the net once a year to keep the column in good condition.

- EPDM O-ring (especially the O-ring of adaptor) may be aged and deformed under long-term compression, so it is recommended to replace it once a year.
- The packed column should avoid exposure to direct sunlight or sudden temperature volatility .
- The chromatography column with medium needs to be treated with antibacterial treatment when it is not used for a long time. Usually, 20% ethanol is used as the preservation solution. It is recommended to replace with fresh 20% ethanol every three months.
- Prevent bubbles to enter the column during storage. Once bubble enters, repacking is necessary.
- Although most of the stainless steel components are made of 316L stainless steel, rusting and corrosion may still occur under wet and high salt conditions. Thus keep columns away from wet and high salt environment.

5.1 Chemical tolerance

The B XK column components which is exposed to feed liquid are made of four kinds of materials: 316L stainless steel, high borosilicate glass, EPDM, polypropylene and nylon (only limited to 10um screen), and chemical reagents harmful to these four materials should be avoided during use. The following table lists some chemical reagents that may be used for reference.

Substance and concentration	Tolerance	Potential impact	Remarks
Common aqueous solution	Usable	/	/
8M urea	Usable	/	/
Low concentration stain remover (Triton/TBP) ,1%	Usable	/	/
2M NaOH	Usable	/	/
20% ethanol	Usable	/	/
10% acetone	Usable	/	can be used for long time with lower than 10% acetone
50% glycol	Usable	/	/
100% isopropyl alcohol	Usable	/	/
50% acetonitrile	Short-term use	Seal ring to harden	/

2M NaCl	Short-term use	Lead to rust	Chloride ions can cause corrosion of stainless steel, especially in the environment with pH lower than 4. NaCl solution with concentration lower than 2M can be used normally in chromatography. After use, it should be washed with purified water in time. The preservation solution should not contain NaCl.
25% HAC	Short-term use	/	Do not use with 10um nylon mesh
0.1M HCl	Short-term use	/	Do not use with 10um nylon mesh
0.1M HNO ₃	Short-term use	/	Do not use with 10um nylon mesh
Substance and concentration	Tolerance	Potential impact	Remarks
6MGuanidine hydrochloride	Short-term use	Causes corrosion of stainless steel	Rinse with purified water immediately after use
Trichloromethane Dichloromethane	Prohibition of use	Causes the seal ring to dissolve	/
10%H ₂ O ₂	Prohibition of use	Lead to aging of sealing ring	/
Toluene	Prohibition of use	Lead to aging of sealing ring	/

Note: Short-term use can be used during chromatography, but it needs to be washed in time after use.

6. Handling Information

- Chloride ion can easily corrode stainless steel parts, when there is a saline solution sprinkled on the surface of stainless steel, it is necessary to wash with a large amount of purified water in time, and dry with a soft cloth .
- The column is glass product, should be handled with care, do not use hard objects to hit the column.
- Make sure installation, maintenance, operation and testing are carried out by fully trained personnel who understand the operating instructions.
- Personnel should always wear appropriate protective clothing to ensure safety during operation. Special attention should be paid when working near the column.

- The working pressure of the column must not exceed the designed pressure, otherwise there will be danger of injury and column destruction. Appropriate safety equipment must be installed.
- The operating temperature of the column should not exceed the designed temperature range.
- When mounting/dismounting the adaptor, slowly move adaptor downward/upward when the O-ring is loosening. If the O-ring is stuck, gently rotate the cylinder leftwards and rightwards. Do not push/pull it forcibly or shake it to avoid damage to the glass tube.
- Except for the chemicals that have been proven harmless to the column, do not use other chemicals to the column.

7. Appendix

7.1 BXK300 chromatography column structure decomposition Figure 1

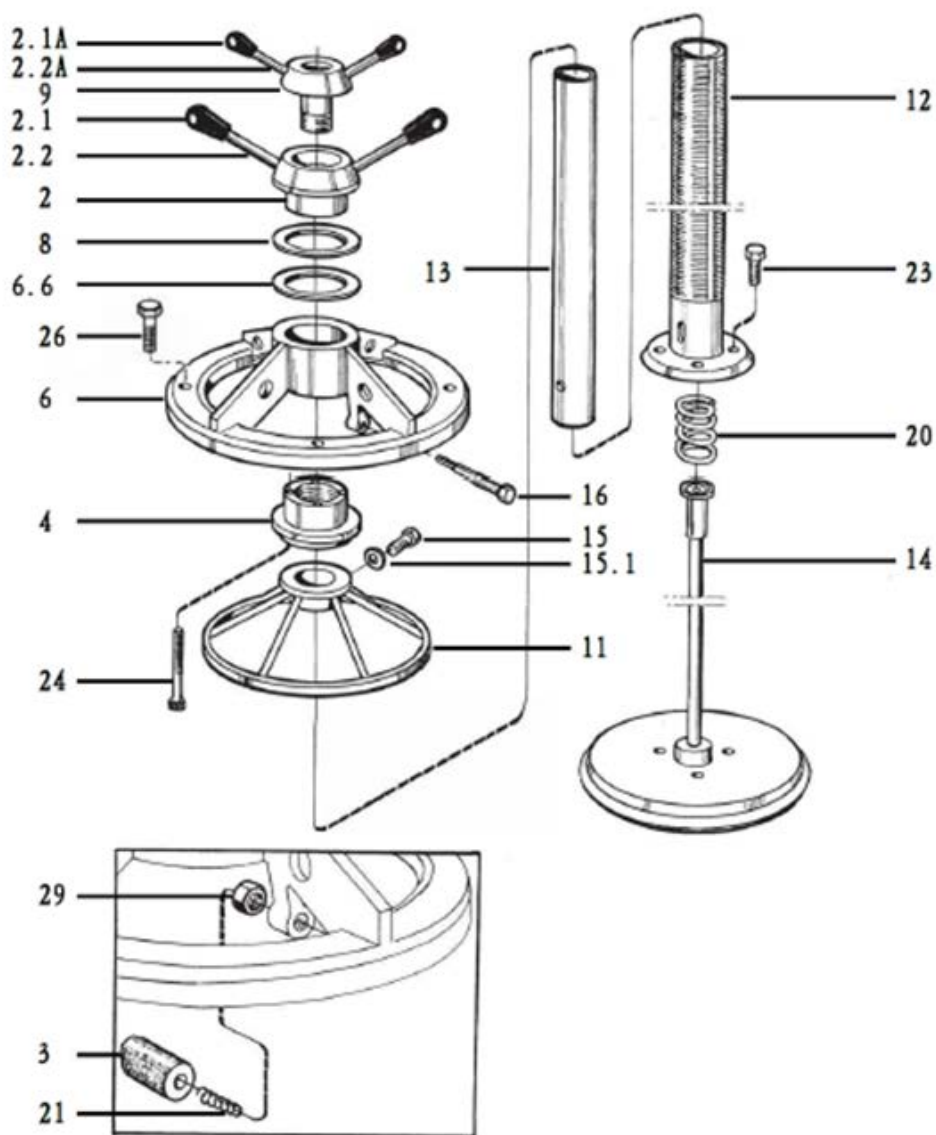

7.2 Structural Decomposition Diagram 2 of BXK300 Chromatography Column

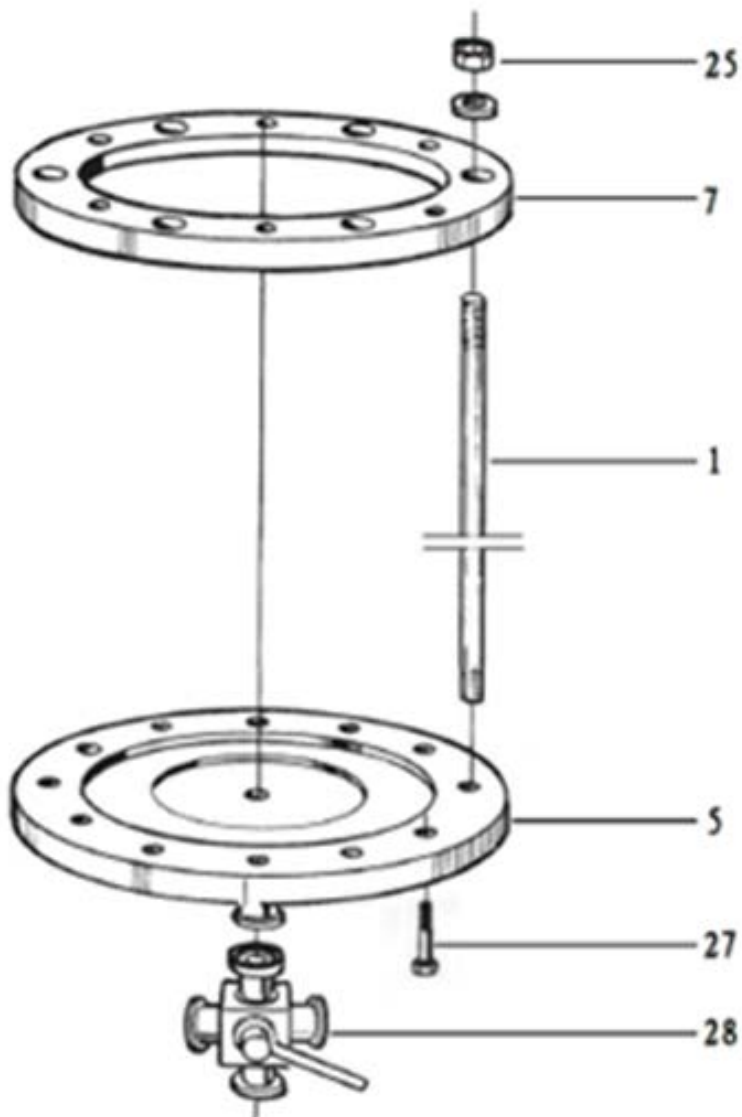

Table Axonometric Diagram of BXK300 Chromatography Column



Number	Name	Product specifications	Quantity per set	Material	Remarks
1	Screw	M12x532/782/982	6	316	Depends on glass tube height 500/750/950
2	Handle wheel	Handle wheel1	6	316L	/
2.1	Handle	Handle ϕ 33x54	2	POM(black)	/
2.1A	Handle	Handle ϕ 26x42	2	POM(black)	/
2.2	Handle bar	Handle barM10x127	2	316	/
2.2A	Handle bar	Handle barM10x67	2	316	/
3	Anti-rotation key	/	1	PTFE	/
4	Nut	/	1	PEEK	/
5	Chassis	/	1	316L	/
6	Hanging	/	1	316L	/
6.6	Shaft sleeve	ϕ 106x ϕ 88.4x15		PTFE	Outer diameter x inner diameter x thickness
7	Flange	/	1	316L	
8	Handle wheel washer	ϕ 119.5x ϕ 90x1	2	PTFE	Outer diameter x inner diameter x thickness
9	Threaded sleeve	/	1	POM(black)	/
11	Sealed unit	/	1	316L	/
12	Adapter outer tube	/	1	316L	/
13	Adapter inner tube	ϕ 30x ϕ 26	1	316L	Outer diameter x inner diameter, seamless tube
14	Adapter disk	/	1	316L	/
15	Screw	M8x28	3	316	/
15.1	Gasket	ϕ 16x ϕ 8.5x1	3	PTFE	Outer diameter x inner diameter x thickness
16	Anti-rotation screw	M10x70	1	316	/
20	Adjusting spring	ϕ 3x ϕ 28x10x65	2	stainless steel	Wire diameter x middle diameter x pitch x height; both ends are ground flat
21	Anti-rotation key spring	ϕ 0.6x ϕ 6.4x3x19	1	stainless steel	Wire diameter x middle diameter x pitch x height; both ends are ground flat
23	bolt	M8x16	4	stainless steel	/
	Standard spring washer	8	4	stainless steel	/
	Flat Washers	8	4	stainless steel	/
24	Socket head cap screws	M8x60	4	stainless steel	/
	External serrated locking flat washer	8	4	stainless steel	/

Number	Name	Product specifications	Quantity per set	Material	Remarks
25	Nut	M10	6	stainless steel	/
	Flat Washers	10	6	stainless steel	/
26	bolt	M10x40	6	stainless steel	/
	Flat Washers	10	6	stainless steel	/
27	bolt	M12x25	6	stainless steel	/
	Nut	M12	6	stainless steel	/
	Flat Washers	12	6	stainless steel	/
28	Four-way valve	4-position 2-way	1	316L	Boreφ6
	4-position 4-way 1	4-position 2-way	1	316L	Boreφ9
29	Nut	M10	1	stainless steel	/

7.3 List of BXK 300 chromatography column components and materials.

Number	Product	Model	Material
1	Seal regulator	/	316L/POM
2	Pillar bed regulator	/	316L/POM
3	Wear ring	/	POM
4	Upper column plate fixing screw	M10×40mm	316L
5	Gasket	M10	316L
6	Dust plug	/	Teflon /PTFE
7	Upper column plate	/	316L
8	Support adjustment unit	/	PEEK
9	Support adjustment unit fixing screw	M8×60mm	316L
10	Anti-rotation bolt thread	/	Stainless steel
11	Anti-rotation key	/	POM
12	Anti-rotation lock screw	/	Stainless steel
13	Anti-rotation screw spring	/	Steel
14	Sealed unit	/	316L
15	Column head seal	/	EPDM
16	Adapter outer tube	/	316L
17	Adapter fixing screws	M8×15mm	316L

Number	Product	Model	Material
18	Gasket	/	316L
19	Adapter inner tube	/	316L
20	Adjusting spring	/	316L
21	Adapter disk	/	316L
22	Deflector	/	Polypropylene /PP
	Support net	/	Polypropylene
23	23um upper screen(300 columns)	/	PP
	10um upper screen(300 columns)	/	Nylon
24	Nut	/	316L
	Gasket	/	316L
25	Flange	/	316L
26	Upper O-ring	/	EPDM
27	Glass tube 500	/	Borosilicate glass
	Glass tube 750	/	Borosilicate glass
	Glass tube 950	/	Borosilicate glass
28	Screw 500	/	316L
	Screw750	/	316L
	Screw950	/	316L
29	Chassis	/	316L
30	Lower O-ring	/	EPDM
31	23umLower screen (300 column)	/	PP
	10umLower screen (300 column)	/	Nylon
32	Lower support net	/	PP
33	Four-point two-way valve	/	316L、Teflon
34	Pole frame	/	316L
35	Pillar fixing screws	/	316L
36	Gasket	/	EPDM
37	Adapter inner tube fixing ring	/	POM

8. Ordering information

Product	Art.No.	Package/piece
BXK300/500 (10um)	BC836211	1
BXK300/500	B-300500	1
BXK300/750 (10um)	BC838211	1
BXK300/750	B-300750	1
BXK300/950 (10um)	BC839211	1
BXK300/950	B-300950	1
Adaptor O-ring (300 columns)	BS830012	2
10µm Net, adaptor (300 columns)	BS820012	2
10µm Net, end piece (300 columns)	BS820032	2
23µm Net, adaptor (300 columns)	BS820022	2
23µm Net, end piece (300 columns)	BS820042	2
Support net, adaptor (300columns)	BS820052	2
Support net, end piece (300columns)	BS820062	2
Glass tube (300/500 columns)	BS816001	1
Glass tube (300/750 columns)	BS818001	1
Glass tube (300/950 columns)	BS819001	1
Four-point two-way valve, 6mm	B-006	1
Four-point two-way valve, 10mm	B-010	1
Four-point four-way valve, 6mm	BA210021	1
Four-point four-way valve, 10mm	BA220021	1
1 "stainless steel clamp	B-0011	1
	BA500016	10
Gasket (TC25, 6.9mm)	B-018	2
	BA500036	10
Gasket (TC25, 12.5mm)	BA500052	2
	BA500056	10
Blind board (TC25)	B-019	2
Blind board (TC50)	BA500072	2
Pressure gauge (TC25 interface, 6bar)	BA500081	1



Product	Art.No.	Package/piece
Pressure gauge (TC25 interface,10bar)	BA500091	1
Pressure gauge (TC50 interface,6bar)	BA500191	1
Pressure gauge (TC50 interface,10bar)	BA500181	1
Three-way (TC25Stainless steel T type)	BA500101	1
Three-way (TC25/TC50Stainless steel T type)	BA500111	1
TC joint PVC pipe,6mm,1.5M	B-0013	1
TC joint PVC pipe,6mm,2M	BA187001	1
TC joint PVC pipe,10mm,1.5M	B-0014	1
TC joint PVC pipe,10mm,2M	BA197001	1
TC connector silicone pipe,6mm,1.5M	B-0015	1
TC connector silicone pipe,6mm,2M	BA187011	1
TC connector silicone pipe,10mm,1.5M	B-0016	1
TC connector silicone pipe,10mm,2M	BA197011	1
Glue stick (80mmplate)	BA500011	1
Glue stick (150mmplate)	BA500021	1
300 Reservoir	B-300-01	1
end-piece O-ring (300columns)	BS830021	1
Adaptor O-ring (300columns)	BS830031	1
Feed port O-ring (300columns)	BS830041	1
Adaptor plate (300 columns)	B300500-34	1
End-piece (300columns)	B300500-12	1
Outer adaptor tube (300columns)	B300500-31	1
Adjuster nut, insert (300columns)	B300500-22	1